

DIMENSION SHEET

STRAIGHT PIN



ENGLISH

Company: _____ Contact person: _____
 City / State: _____ Phone: _____
 Country: _____ Fax: _____ Email: _____
 Order Inquiry Quantity: _____ pcs Measured by: _____
 Machine make & model: _____ Machine year: _____
 Machine Serial No: _____ Original pin part number: _____
 Pin location on machine: _____

PIVOT DIMENSION

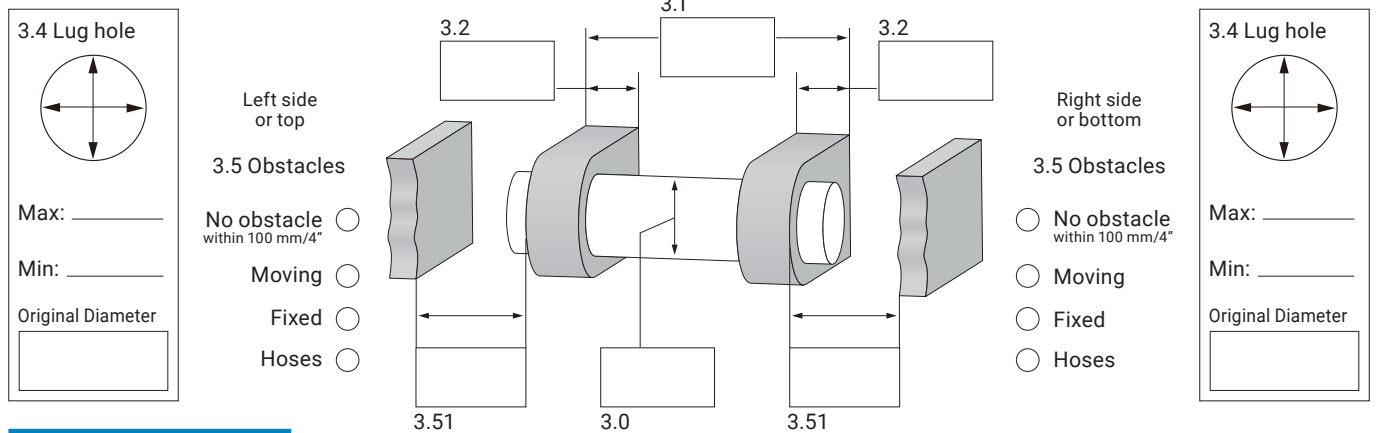
 Measurements in: Inches mm

GREASING

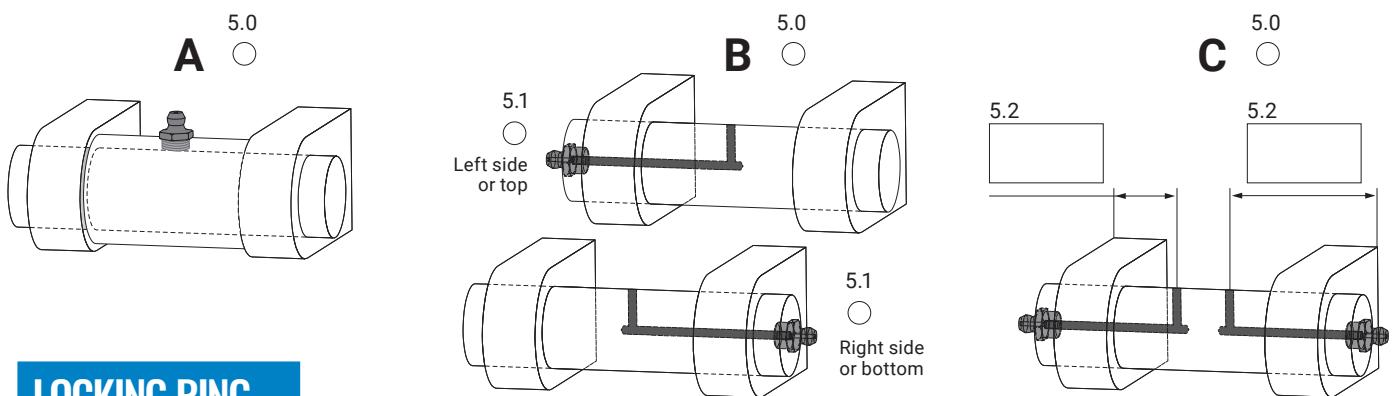

LOCKING RING

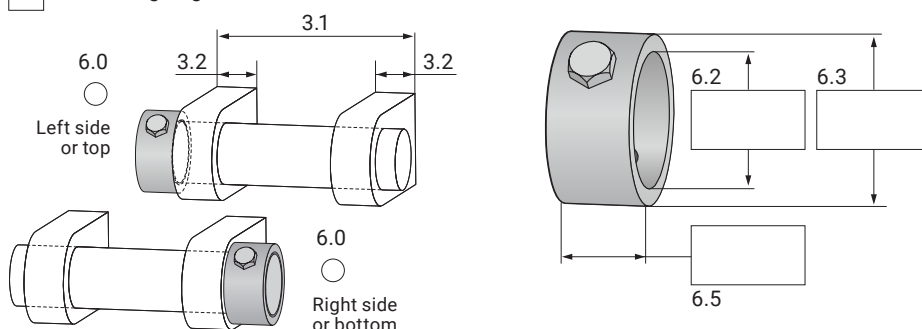
 No locking ring

DIMENSION SHEET

STRAIGHT PIN



PIVOT DIMENSION

- 3.0 Original pin diameter. The diameter is usually an standard axle diameter.
As a service Expander System helps to choose a suitable tolerance for the application.
- 3.1 Measure the distance between the outside edges of the mounting lugs.
Measuring accuracy +/- 1 mm (+/- 0,04").
- 3.2 Measure the width of respective mounting lug.
Measuring accuracy +/- 1 mm (+/- 0,04").
- 3.4 Fill in the original diameters of the holes of the mounting lugs (bushings removed if applicable). If the holes are more than 1,5 mm (0,06") worn measure the maximum and minimum diameters of the worn holes. Measuring accuracy +/- 0,2mm (+/- 0,008").
- 3.5 If there are obstacles within 100 mm (4") from the outside of respective mounting lug, indicate type of obstacle (moving, fixed or hoses).
- 3.51 If obstacles indicated in 3.5, measure the distance between respective outside edge of mounting lug and obstacle. Measuring accuracy +/- 1 mm (+/- 0,04").

GREASING

- 5.0 Indicate the grease distribution of the pivot.
A=external greasing,
B= greasing through pin (one outlet centred between the inner edges of the lugs),
C= greasing through pin (two outlets).
- 5.1 If B, indicate from which side the pivot is greased.
- 5.2 If C, measure the greasing outlet distance from respective outside edge of mounting lug.
Measuring accuracy +/- 1 mm (+/- 0,04").

LOCKING RING

- 6.0 If there is no locking ring please mark "No locking ring". If there is a locking ring, indicate on which side the ring is situated and proceed with 6.2, 6.3 and 6.5.
- 6.2 Measure locking ring inner diameter. Measuring accuracy +/- 0,5 mm (+/- 0,02").
- 6.3 Measure locking ring outer diameter. Measuring accuracy +/- 1 mm (+/- 0,04").
- 6.5 Measure locking ring width. Measuring accuracy +/- 1 mm (+/- 0,04").



For stepped pins, please use the dimension sheet for stepped pins.